



PA10VSO Series 31

Axial piston variable pump

Used for hydraulic drives in open loop circuits

Features:

- Swashplate axial piston pump.
- Adjust the angle of swashplate to realize the stepless variable.
- Good suction characteristic.
- Have the structural design of compact, light weight, low noise characteristics.
- The sensitivity of control system.
- Flow is proportional to the drive speed and to the displacement.
- Nominal pressure reach to 28 Mpa.
- Long service life, high-precision bearings.
- Hydrostatic balance slipper, improve the life of pump.
- Axial and radial loading of drive shaft possible

* Ordering Code

PA10V(S)	O	28	DR	/	31	R	-	P	S	C	62	N00
Pump model	Operating mode	Size	Control mode		Series	Direction of rotation		Sealing material	Shaft end	Mounting flange	Working port	Through drive

* Model Description

Axial piston unit

Model variable pump, swash plate design Rated pressure 280bar Peak pressure 350bar	PA10V(S)
--	----------

Type of operation

Pump, open circuits	O
---------------------	---

Size

Displacement (ml/r)	18	28	45	71	100	140	
---------------------	----	----	----	----	-----	-----	--

Mode of operation

Two point, direct control	✓	✓	✓	✓	✓	✓	DG
Pressure control	✓	✓	✓	✓	✓	✓	DR
Remote Pressure control	✓	✓	✓	✓	✓	✓	DRG
Pressure and flow control	✓	✓	✓	✓	✓	✓	DFR
Pressure and flow control Orifice in X-channel closed	✓	✓	✓	✓	✓	✓	DFR1
Pressure, flow, torque control		✓	✓	✓	✓	✓	DFLR

Series

Products series	31
-----------------	----

Direction of rotation

With view on shaft end	Clockwise	R
	Counterclockwise	L

Seals

NBR Nitrile rubber	P
FKM Fluoro-rubber	V

Shaft end

	18	28	45	71	100	140	
Metric parallel with key	✓	✓	✓	✓	✓	✓	P
SAE splined	✓	✓	✓	✓	✓	✓	S
SAE splined (higher through drive torque)	✓	✓	✓	✓	–	–	R
SAE parallel with key	✓	✓	✓	✓	✓	✓	K
SAE splined reduced dia, Not for through drive	✓	–	✓	–	✓	–	U
Similar to shaft "U", higher input torque, not for through drive	–	–	✓	–	✓	–	W

Mounting flange

	18	28	45	71	100	140	
ISO 2-hole	✓	✓	✓	✓	✓	–	A
SAE 2-hole	✓	✓	✓	✓	✓	–	C
ISO 4-hole	–	–	–	–	–	✓	B
SAE 4-hole	–	–	–	–	–	✓	D

Service ports

SAE flange rear, fixing thread metric	–	✓	✓	✓	✓	✓	11
SAE flange rear, fixing thread NUC	–	✓	✓	✓	✓	✓	61
SAE flange on opposite side, fixing thread metric	✓	✓	✓	✓	✓	✓	12
SAE flange on opposite NUC	✓	✓	✓	✓	✓	✓	62
SAE flange rear, fixing thread metric (NUC)	–	–	–	✓	–	–	41(91)
SAE flange on opposite side, fixing thread metric (NUC)	–	–	–	✓	–	–	42(92)

Through drive

With through drive to accept an axial piston pump or gear pump

	18	28	45	71	100	140	
Without through drive	✓	✓	✓	✓	✓	✓	N00

* Technical Data

Operating pressure range-inlet

Absolute pressure at port S

Pabs min 0.8 bar

Pabs max 30 bar

Operating pressure range-inlet

Pressure at port B

Normal pressure PN 280 bar

Peak pressure Pmax 350 bar

Applications with intermittent operating pressures up to 315 bar at 10% duty are permissible.

Case drain pressure

Maximum permissible pressure of leakage fluid (at port L, L1);

Maximum 0.5bar higher than the inlet pressure at port S, but no higher than 2bar absolute.

Size	18	28	45	71	100	140	
Displacement (V_{gmax})	cm ³ /r	18	28	45	71	100	140
Max.speed (n_{max})	rpm	3300	3000	2600	2200	2000	1800
Max.Output flow	in n_{max} q_v L/min	59.4	84	117	156	200	252
	in 1500r/min q_v L/min	27	42	68	107	150	210
Max.power	in n_{max} P_{max} KW	27.7	39	55	73	93	118
	in 1500r/min P_{max} KW	12.6	20	32	50	70	98
Max.torque ($\Delta P=280bar$) in N.m	V_{gmax} T_{max}	80.1	125	200	316	445	623
Weight(approximately)	m kg	12	15	21	33	45	60

Parameter calculation

$$\text{Flow } q_v = \frac{V_g \cdot n \cdot \eta_v}{1000} \text{ [L/min]}$$

$$\text{Drive torque } T = \frac{1,59 \cdot V \cdot \Delta P}{100 \cdot \eta_{mh}} = \frac{V_g \cdot \Delta P}{20\pi \cdot \eta_{mh}}$$

$$\text{Drive power } p = \frac{T \cdot n}{9549} = \frac{2\pi \cdot T \cdot n}{60000} = \frac{q_v \cdot \Delta p}{600 \cdot \eta_t} \text{ [kW]}$$

V_g = Geometry displacement each rotate [cm³]

ΔP = Pressure drop/differential [bar]

n = Rotary speed [rpm]

η_v = Cubage's efficiency

η_{mh} = Mechanical hydraulic efficiency

$\eta_t = (\eta_t = \eta_v \cdot \eta_{mh})$ Overall efficiency

* Operation Mode

DG - Two-point control, direct operated

The variable pump can be set to a minimum swivel angle by connecting an external switching pressure to port X.

This will supply control fluid directly to the stroking piston; a minimum control pressure of $p_{st} \geq 50$ bar is required. The variable pump can only be switched between $V_{g,max}$ or $V_{g,max}$. Please note that the required control pressure at port X is directly dependent on the actual working pressure p_b in port B. (See control pressure characteristic curve).

Control pressure P_{st} at $X=0$ bar = $V_{g,max}$

Control pressure P_{st} at $X \geq 50$ bar = $V_{g,min}$

The maximum permissible switching pressure is 280 bar.

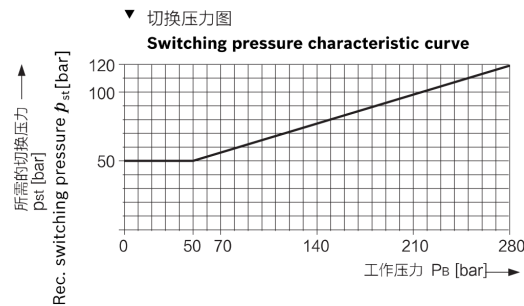
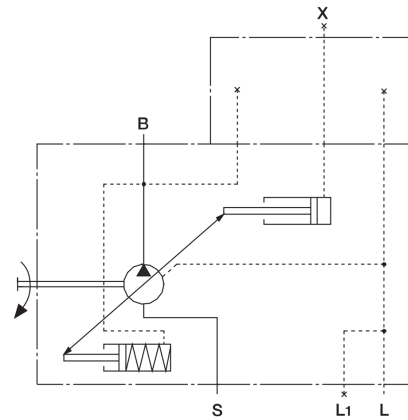

Oil port

- B Working port
- S Suction port
- L, L1 Drain port (L1 close)
- X Pilot pressure port (close)

DR - Pressure control

In the control range of the pump, the pressure in the hydraulic system is kept constant. Therefore, the pump only provides the hydraulic oil required for the actuator. Pressure can be set in the control valve.

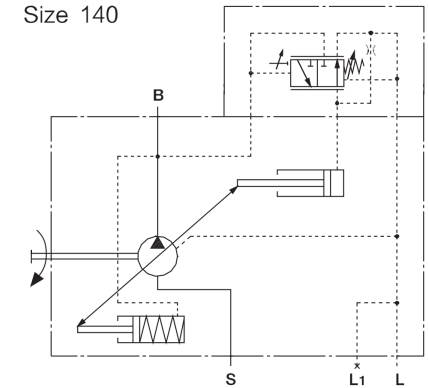
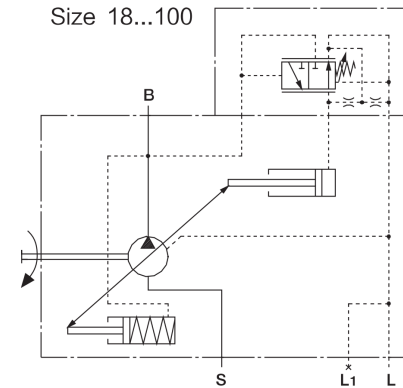

Characteristic curve

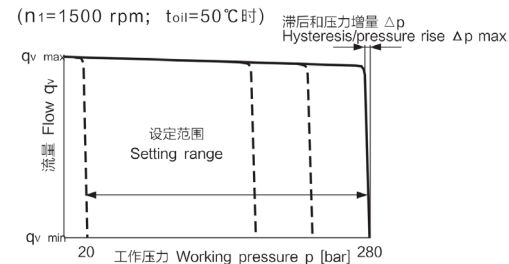

Left curve shows the average value of the test conditions. Condition: $n=1500$ rpm; $t_{oil}=50^\circ\text{C}$. The main overflow valve is located in 350bar. Using the distance pump pressure from the oil port downstream 1m of the overflow valve, quickly open or close the pressure line, can achieve the classification load

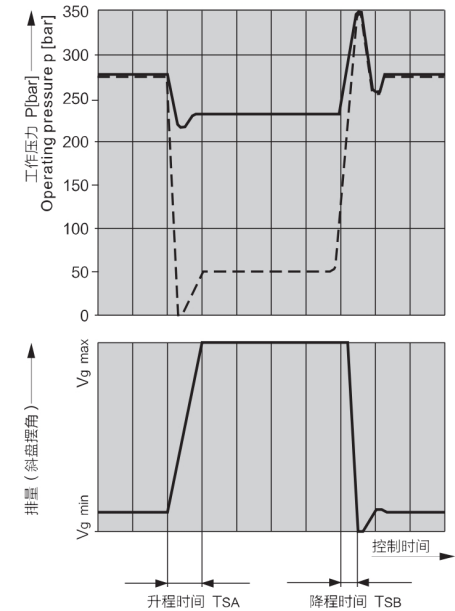

Oil port

- B Working port
- S Suction port
- L, L1 Drain port (L1 close)
- X Pilot pressure port (close)

Control data

Hysteresis and repeatability Δp [bar]
maximum 3

Controller time

Size	18	28	45	71	100	140
t_{SA} [ms] 50bar	50	60	80	100	125	130
t_{SA} [ms] 220bar	25	30	40	50	90	110
t_{SA} [ms] 280bar	20	20	20	25	30	30

Pressure increase

Size	18	28	45	71	100	140
ΔP bar	4	4	6	8	10	12

Pilot fluid consumption [l/min]
maximum approx. 3L/min

DRG - Remote pressure control

The remote control can be realized by connecting an overflow valve with the oil port X. However, the overflow valve is not included in the DRG control of the supply range. DRG control valve core standard pressure is located in 20bar, the pressure difference generated 1.5L/min control flow. For other settings, please use the text description. We recommend using the following one as a separate relief valve: according to the RC25402 of DBD6 (hydraulic), or by RC29166 DBETR-S0381,P with throttle hole whose diameter is $\phi 0.8$ (control). The maximum length of the pipe shall not exceed 2m

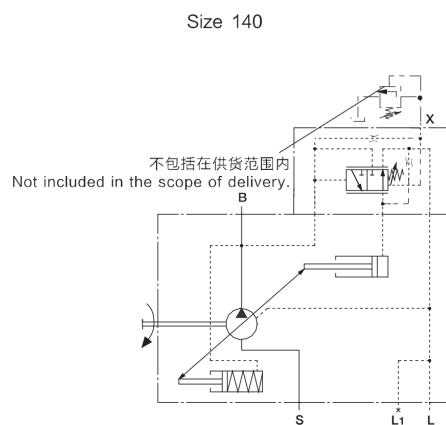
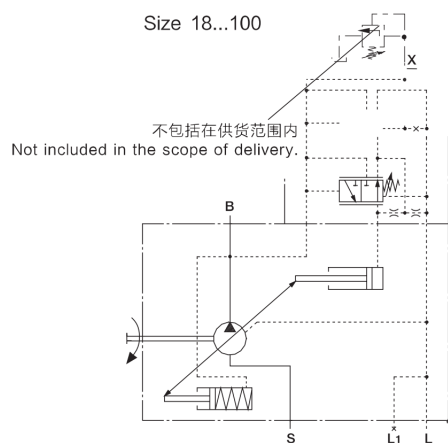

Characteristic curve

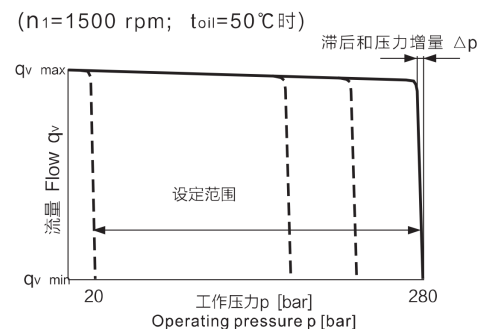

Oil port

- B Working port
- S Suction port
- L, L1 Drain port (L1 close)
- X Pilot pressure port

Controller data

Hysteresis Δp _____ maximum
3 bar

Pressure increase

Size	18	28	45	71	100	140
ΔP bar	4	4	6	8	10	12

Pilot fluid consumption
approx. 3L/min

DFR/DFR1 - Pressure / flow control

In addition to the pressure control function, but also through the differential pressure (such as the throttle valve or valve on the pressure difference) to regulate the flow of the pump flow. Pump to provide the oil needed for the actuator. In the DFR1 type, the throttle hole between the fuel tank is blocked.

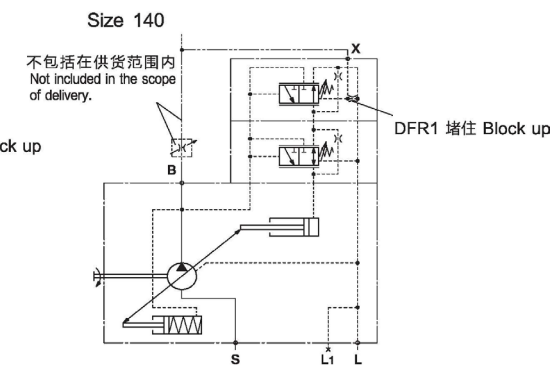
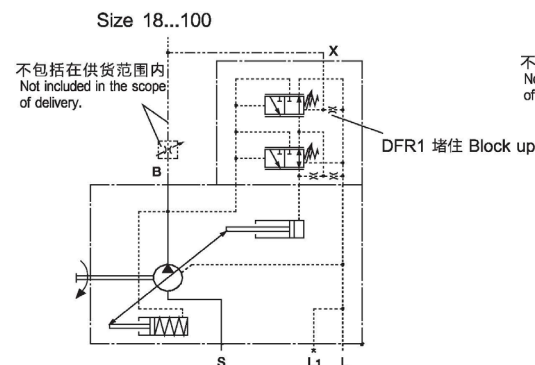

静态特性曲线 Characteristic curve
($n_1=1500$ rpm; $t_{oil}=50^\circ\text{C}$ 时)

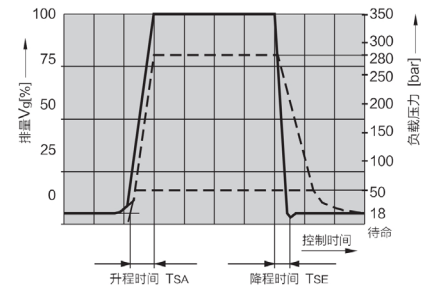
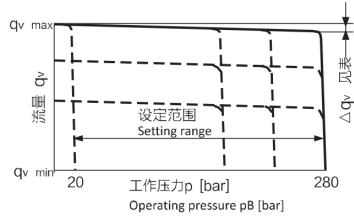

变转速情况下的静态特性曲线
Characteristic curve at variable rotational speed

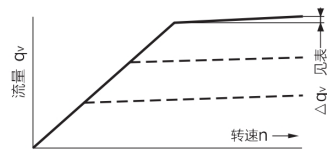

流量控制的动态特性曲线所示曲线是在测试条件下测量的平均值。
Characteristic curve valid at $n_1 = 1500$ rpm and θ fluid = 50°C .

Oil port

- B Working port
- S Suction port
- L, L1 Drain port (L1 close)
- X Pilot pressure port

Differential pressure Δp :

- 1、 Standard setting: 14bar
If another setting is required, please state in plain text.
- 2、 Setting range: 14bar to 22bar
Relieving the load on port X to the reservoir results in a zero stroke ("standby") pressure which lies about 1 to 2bar higher than the defined differential pressure Δp , however, system influences are not taken into account.

DFLR – Pressure / flow / power control

In order to obtain a constant driving torque in the case of working pressure change, by changing the angle of the axial piston element, thus changing the output flow, so that the product of flow and pressure remain constant. Flow control can only be in the constant power control curve.

Size 28...100

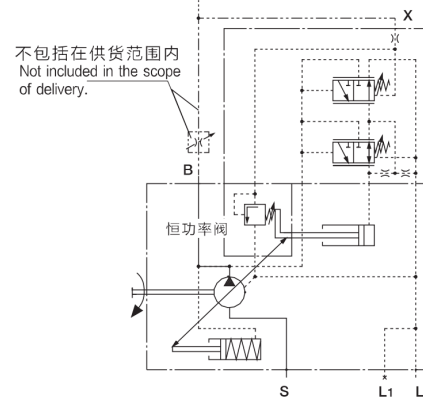

Size 140

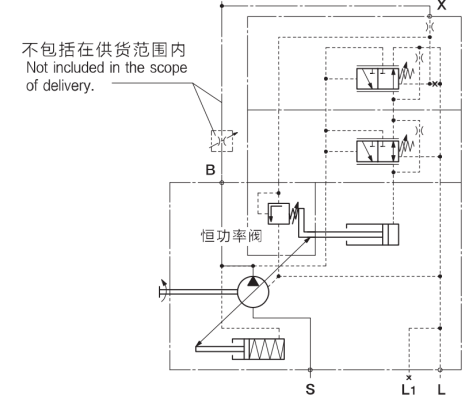

Controller time

Size	18	28	45	71	100	140
t_{SA} [ms] 50bar	50	60	80	100	125	130
t_{SA} [ms] 220bar	25	30	40	50	90	110
t_{SA} [ms] 280bar	20	20	20	25	30	30

Controller data

DR pressure controller data see page 39. Maximum flow deviation measured at drive speed $n = 1500$ rpm.

Size	18	28	45	71	100	140
Δq_{vmax} L/min	0.9	1.0	1.8	2.8	4.0	6.0

静态特性曲线 Characteristic curve

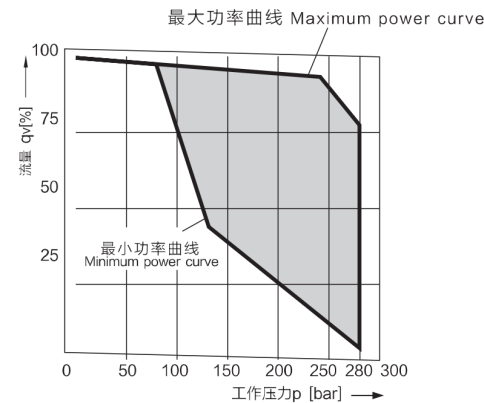

Oil port

- B Working port
- S Suction port
- L, L1 Drain port (L1 close)
- X Pilot pressure port

When ordering please state the power characteristics to be set at the factory in plain text, e.g. 20 kW at 1500 rpm.

For technical data of pressure controller DR see page 4 right.

For technical data of flow controller FR see page 6 left.

Beginning of control at < 80bar

Control fluid consumption approx. 5.5 l/min max.

* Dimintions & Size

Dimensions, Size PA10VSO-18
Installation and connection size 18, N00 without valve

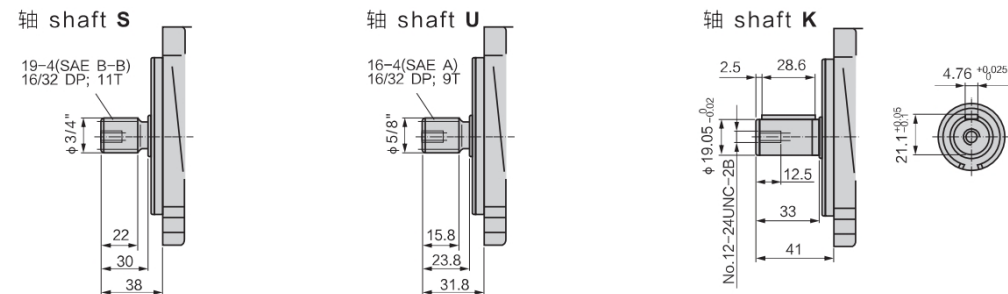
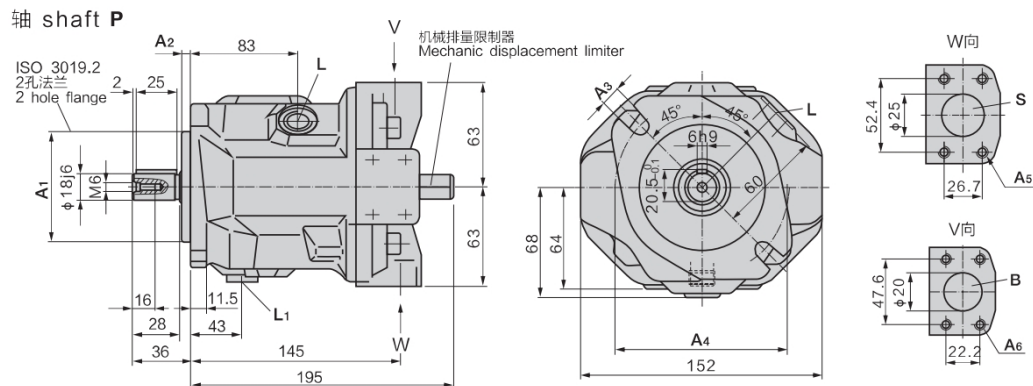

B SAE 3/4" Working port(standard pressure series)
S SAE 1" Suction port(standard pressure series)
L/L₁ Drain port(L₁ as been blocked in the factory)

Size	A ₁	A ₂	A ₃	A ₄	A ₅	A ₆	Port L/L ₁
18 ISO	ø80h8	7	11	ø109	4-M10 deep 17	4-M10 deep 17	M16 x 1.5
18 SAE	ø82.55h8	6.3	11	ø106.4	4-3/8-16UNC- 2B deep 20	4-3/8-16UNC- 2B deep 20	9/16-18UNF- 2B

* Dimintions & Size

Dimensions, Size PA10VSO-28
Installation and connection size 28, N00 without valve

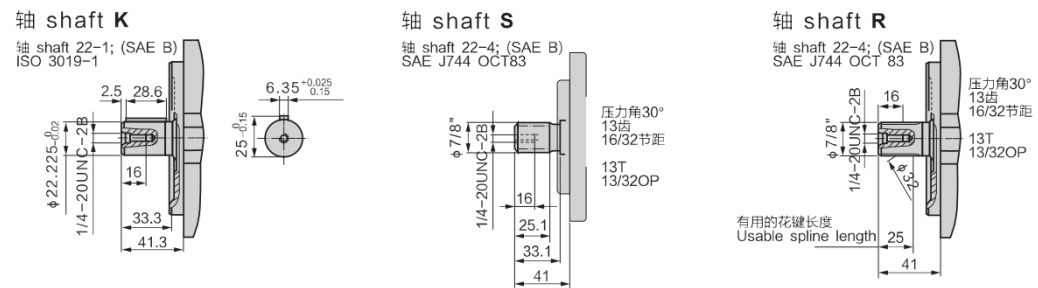
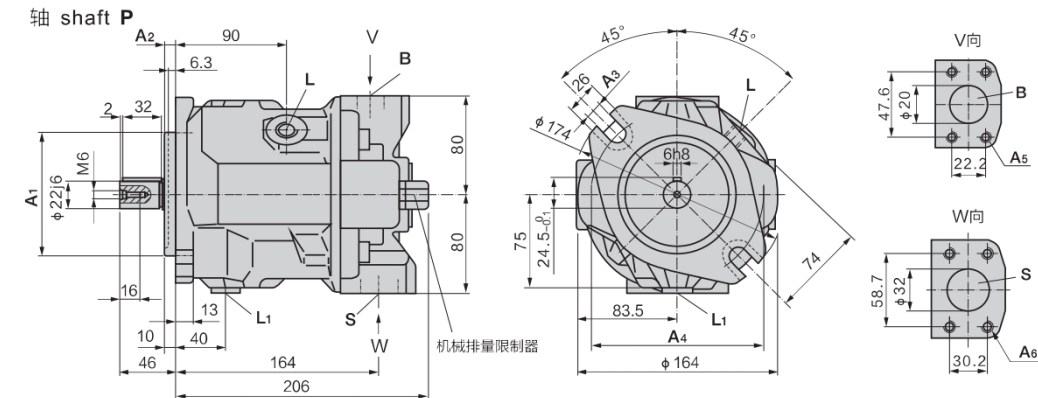

B SAE 3/4" Working port(standard pressure series)
S SAE 1" Suction port(standard pressure series)
L/L₁ Drain port(L₁ as been blocked in the factory)

Size	A ₁	A ₂	A ₃	A ₄	A ₅	A ₆	Port L/L ₁
28 ISO	ø100h8	9	14	ø140	4-M10 deep 17	4-M10 deep 17	M18 x 1.5
28 SAE	ø101.6h8	9.5	ø14	ø146	4-3/8-16UNC- 2B deep 18	4-7/16-14UNC- 2B deep 24	3/4-16UNF- 2B

* Dimintions & Size

Dimensions, Size PA10VSO-45

Installation and connection size 45, N00 without valve

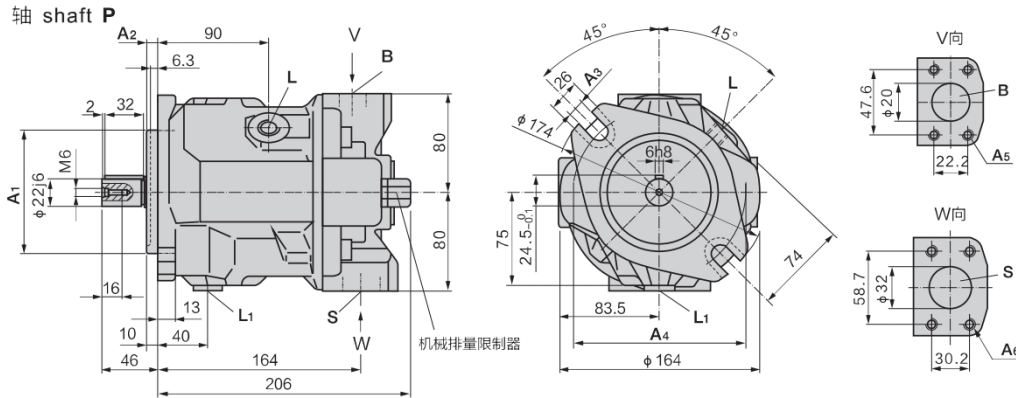

轴 shaft K

轴 shaft 22-1; (SAE B)
ISO 3019-1

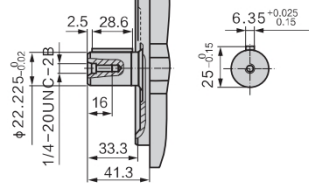

轴 shaft S

轴 shaft 22-4; (SAE B)
SAE J744 OCT83

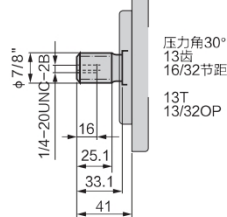

轴 shaft R

轴 shaft 22-4; (SAE B)
SAE J744 OCT 83

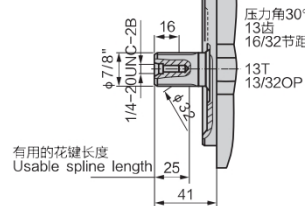

B SAE 3/4" Working port(standard pressure series)
S SAE 1" Suction port(standard pressure series)
L/L₁ Drain port(L₁ as been blocked in the factory)

Size	A ₁	A ₂	A ₃	A ₄	A ₅	A ₆	Port L/L1
45 ISO	ø100h8	9	14	ø140	4-M10 deep 17	4-M10 deep 20	M22 x 1.5
45 SAE	ø101.6h8	9.5	ø14	ø146	4-3/8-16UNC- 2B deep 18	4-1/2-13UNC- 2B deep 22	7/8-14UNF- 2B

* Dimintions & Size

Dimensions, Size PA10VSO-71

Installation and connection size 71, N00 without valve

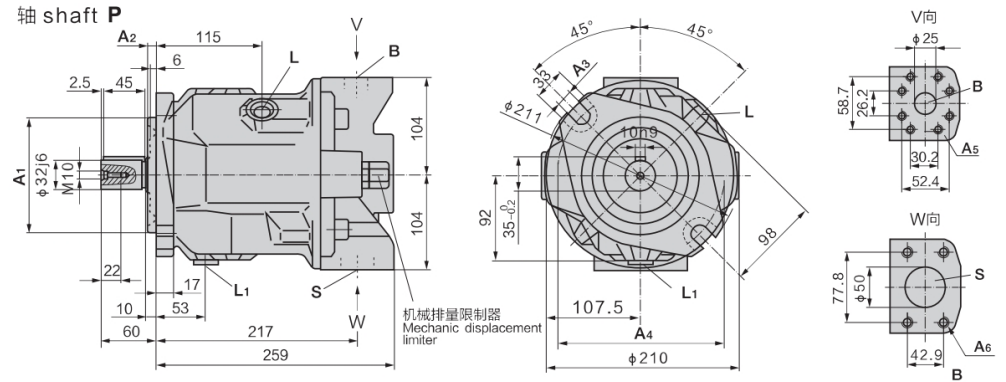

轴 shaft K

轴 shaft 32-1; (SAE C)
ISO 3019-1

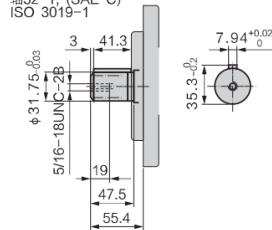

轴 shaft S

轴 shaft 32-4; (SAE C)
SAE J744 OCT83

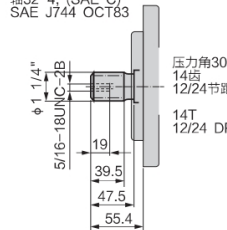

轴 shaft R

轴 shaft 32-4; (SAE C)
SAE J744 OCT 83

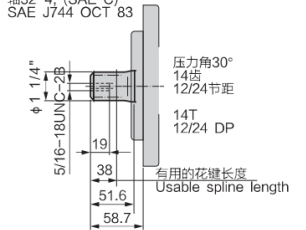

B SAE 3/4" Working port(standard pressure series)
S SAE 1" Suction port(standard pressure series)
L/L₁ Drain port(L₁ as been blocked in the factory)

Size	A ₁	A ₂	A ₃	A ₄	A ₅	A ₆	Port L/L1
71 ISO	ø125h8	9	18	ø180	8-M10 deep 17	4-M12 deep 20	M22 x 1.5
71 SAE	ø127h8	12.7	ø18	ø181	8-3/8-16UNC- 2B deep 18	4-1/2-12UNC- 2B deep 22	7/8-14UNF- 2B

* Dimintions & Size

Dimensions, Size PA10VSO-100

Installation and connection size 100, N00 without valve

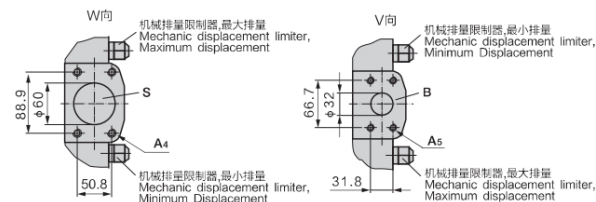
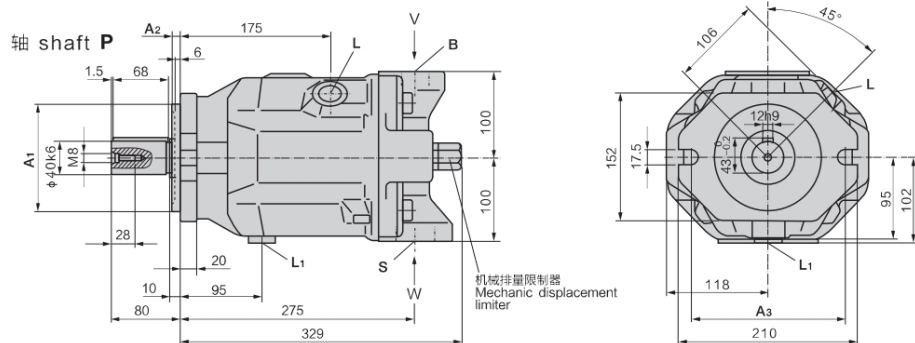

轴 shaft K

轴38-1; (SAE C-C)
ISO 3019-1

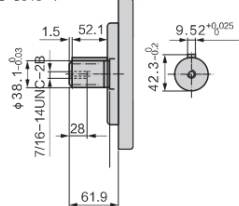

轴 shaft S

轴38-4; (SAE C-C)
SAE J744 OCT83

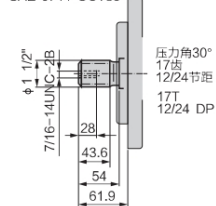

轴 shaft U

轴32-4; (SAE C)
SAE J744 OCT 83

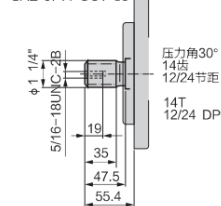

B SAE 1 1/4" Working port(standard pressure series)
S SAE 2 1/2" Suction port(standard pressure series)
L/L₁ Drain port(L₁ as been blocked in the factory)

Size	A ₁	A ₂	A ₃	A ₄	A ₅	A ₆	Port L/L1
100 ISO	ø125h8	9	180	ø180	4-M12 deep 17	4-M14 deep 17	M27 x 2
100 SAE	ø127h8	12.7	181	ø181	4-1/2-13UNC-2B deep 27	4-1/2-13UNC-28-2B deep 18	11/16-12UNF-2B

* Dimintions & Size

Dimensions, Size PA10VSO-140

Installation and connection size 140, N00 without valve

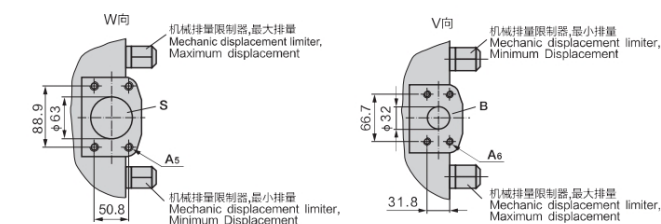
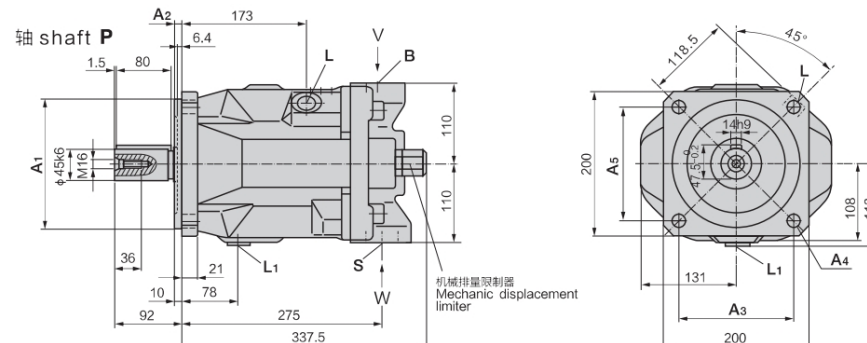

轴 shaft K

轴 shaft 44-1; (SAE D)
ISO 3019-1

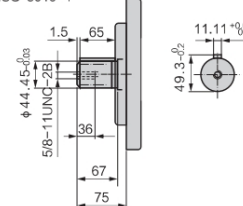

轴 shaft S

轴 shaft 44-4; (SAE D)
SAE J744 OCT83

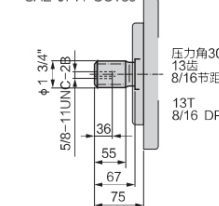

B SAE 1 1/4" Working port(standard pressure series)
S SAE 2 1/2" Suction port(standard pressure series)
L/L₁ Drain port(L₁ as been blocked in the factory)

Size	A ₁	A ₂	A ₃	A ₄	A ₅	A ₆	Port L/L1
140 ISO	ø180h8	9	158.4	4-ø18	4-M12 deep 17	4-M14 deep 19	M27 x 1.5
140 SAE	ø152.4h8	12.7	161.6	4-ø20	4-1/2-13UNC-2B deep 27	4-1/2-13UNC-2B deep 19	11/16-12UNF-2B